



Drawer Construction

Wooden

Traditional dovetails

- Dovetails are one of the strongest joints because of all of the surfaces that can be glued.
- Dovetails are also very pleasing to look at.
- They can be a feature of the item of furniture.
- Dovetails slope at 1:6 or 1:8
- Front drawer dovetails 1:8 back 1:6
- For lap dovetails the socket is approx $\frac{3}{4}$ of the front thickness
- For appearance the tails are usually equal in width.

Drawer

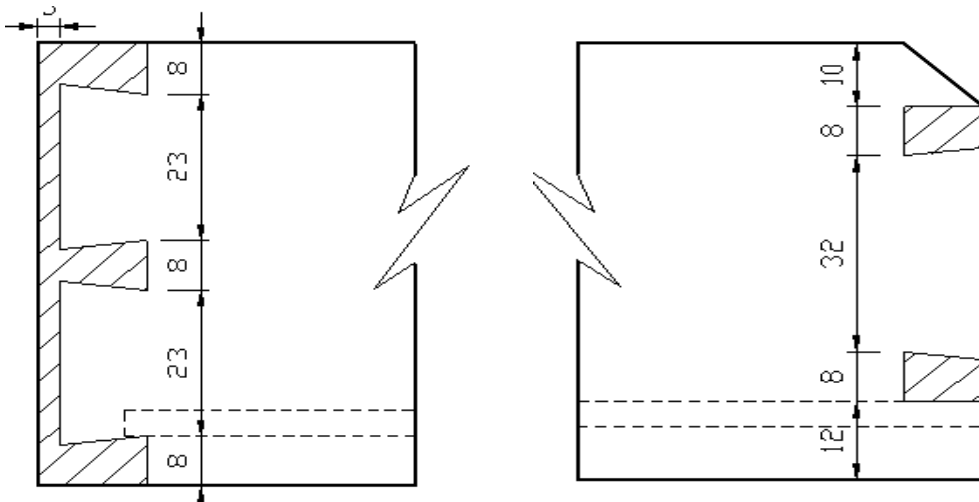

- Lapped dovetails are used on the front of drawer, no end grain showing on the front.
- Through dovetails are used on the back, end grain showing on both sides.
- This view is from the outside notice drawer bottom is dotted ie. Hidden detail
- Drawer bottom should always be grooved inside the socket so that it does not show on the outside.
- Drawer back is usually lower than sides.

Drawing Dovetails

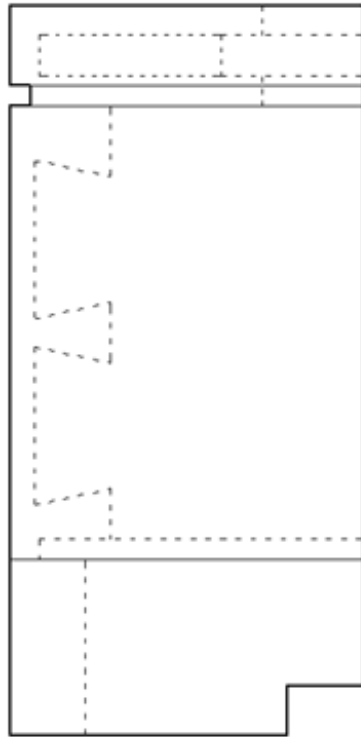

All hidden detail
is dotted

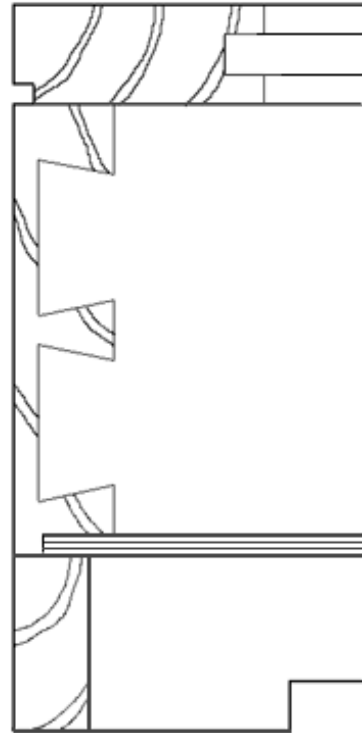

Section through
Trinket Box

- Carcase is rebated to accommodate the bottom

Types of Drawer Fronts

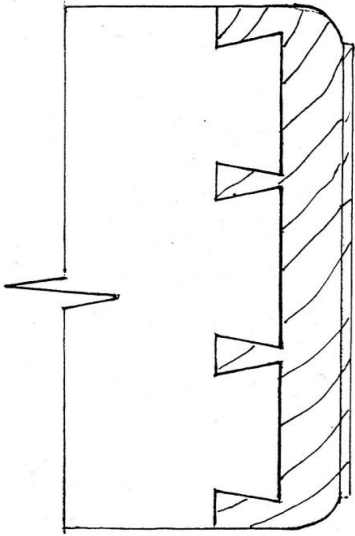

Moulded Front

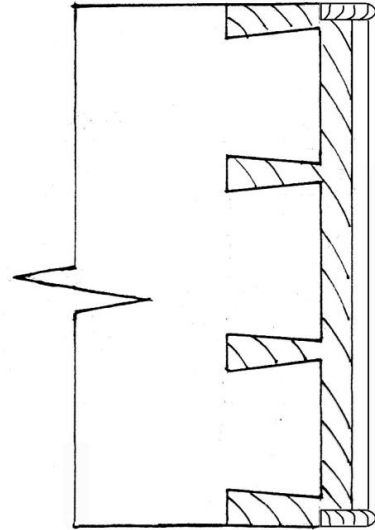

Cock Beaded

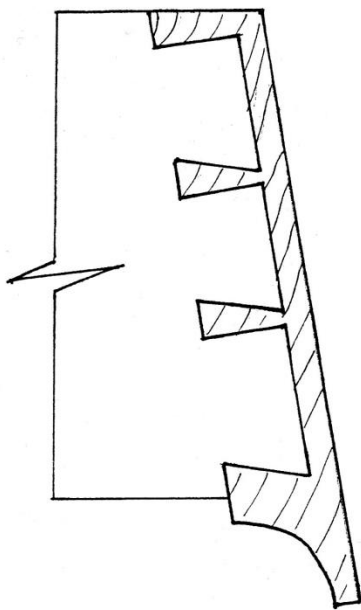

Louvered Front

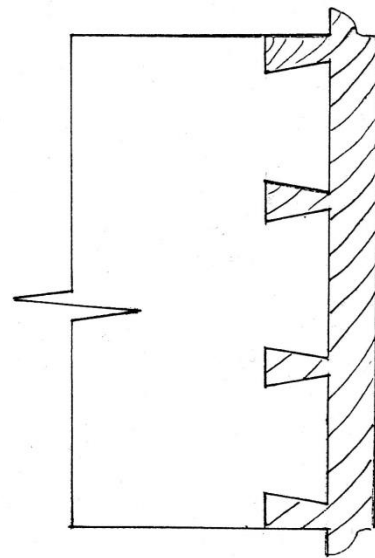

Moulded & Overlapped

Drawer Terms

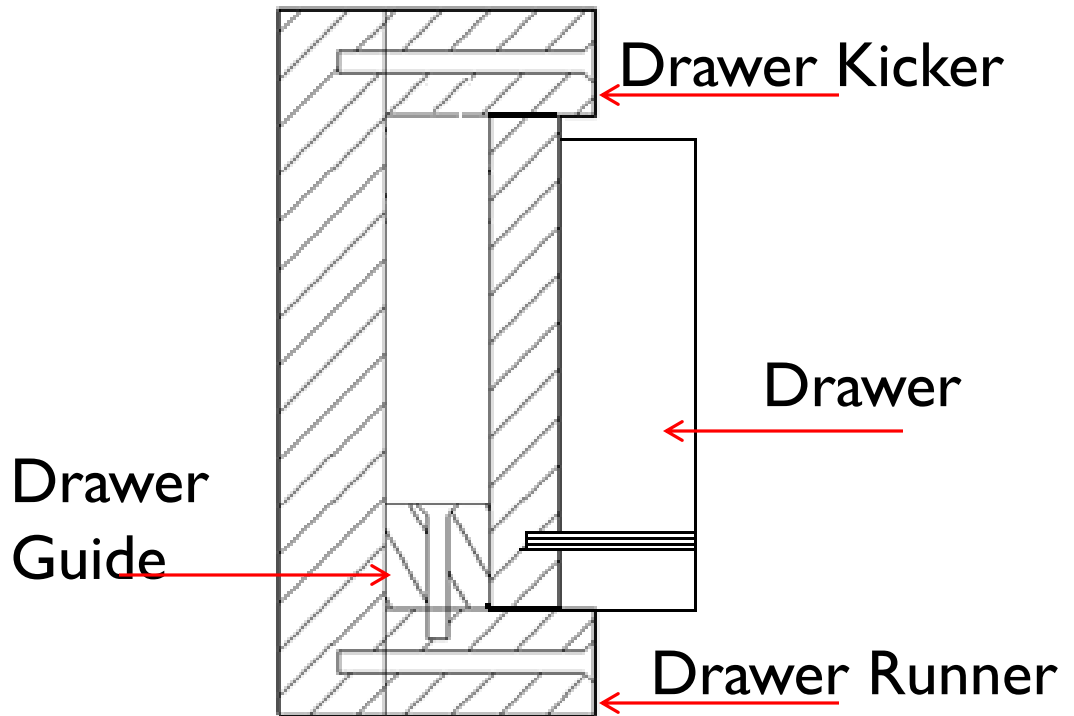

- **Drawer Runner:** This supports the drawer sides.
- **Drawer Kicker:** This prevents the drawer from tipping downwards when opened.
- **Drawer Guide:** This guides the drawer in straight between the frame.

Drawer Terms

