



Student's Name:

Darren Morris

Student Number:

Dublin Institute of Technology
Faculty of the Engineering and Built Environment
School of Construction
Dept. of Construction Skills
Bachelor of Technology in Timber Product Technology

Course Code:	DT169
Academic Year:	2014/15
Semester:	1
Module:	Bespoke Machining
Lecturer:	Jennifer Byrne
Year:	2

I declare that the work contained in this submission is my own work and has not been taken from the work of others save to the extent that such work has been cited within the text of this submission.

Signed:

Date:

Darren Morris

Principles of Furniture and Joinery Design

Bespoke Machining

Half sheet MDF Table

Table of contents:

	Page No.
<u>Introduction</u>	1
<u>Design objectives</u>	2
<u>Methodology</u>	6
<u>Sketches</u>	7
<u>Estimated time scale</u>	13
<u>Cutting list</u>	14
<u>Works cited</u>	17

Introduction:

Within this report will be a discussion on the concept of my design and the initial thought process I went through to manufacture the table out of the half sheet of mdf which measures 1220mm x 1220mm x 18mm. I came to my final design by researching other similar ideas on the internet and coming up with my own ideas through rough sketching, designing. I found it was hard to come up with a design that is not similar to those that are already seen on the market today. In today's market regarding tables there is a wide variety of designs and sizes of tables which people are for ever coming up with new ideas that have not yet been seen. After sketching a wide variety of ideas for which I thought have not yet been seen in market I finally came up with a final design for which I think incorporates the specifications that are stated in the brief such as the curved elements. It took a lot of sketching and designing to construct a design that will fit the brief and be attractive for someone to buy. There was a lot of factors to consider when designing this table out of half sheet of mdf such as only having a half sheet of the material to work with meaning I had to carefully plan and measure each piece individually allowing myself enough material to make the table. I had to also plan the table in such a way that it was easy to construct as we were not allowed to use hand tools in the manufacturing of this table only power tools and the wall saw in room 109 in the breaking out of material. Within this half sheet of mdf we also had to construct jigs or templates that required so planning was a crucial factor to consider in manufacturing the table. Using only power tools to construct the table was a problem I had to overcome when designing, if I had pieces that could not be cut from power tools the table would be able to be manufactured so designing them in a way to fit together using power tools was a factor I had to consider. From looking at other tables I decided to change the shape of the table top from the common square or round tops to an elliptical shape as I believe the square edges on the square table top can be a hazard sometimes as you walk into them or hit off them so I decided to go with an elliptical shape to prevent this from happening. The elliptical top also fits the brief as it shows the curved element required by the brief. As you look at my final design you can see how I have related it to the current standards required and have built it to fit suitable ergonomics of tables. The table I designed I believe will be of suitable height and will be of appropriate size for the area where it will be situated.

Design objectives:

Function:

The table I have designed will be used in a conventional sitting room or dining room as a coffee table. It will be of appropriate height so it can also be used as a footrest opposite the sitting room couch. The table is to be used in front of a sitting room couch for placing beverages e.g. coffee, and for placing books, magazines or any other items such as small ornaments or souvenirs that will be located in a sitting room. It can also be used for placing a laptop or iPad on while in use.



Image 1

Proportion:

When designing the sizes of my table I done research on other tables to see what the average sizes they are, from researching I have learned that the standard height of the table ranges from 400mm – 460mm but may go higher and is generally the same height as the seat or 25mm – 50mm below the seat height. The standard width of a coffee table is usually 2/3 of the couch not including the arms and the width will depend on the amount of room that is available where it will be situated. I have designed my table so that it fits between the standard measurements of a coffee table but may become smaller due to the fact that there is shortage of material.

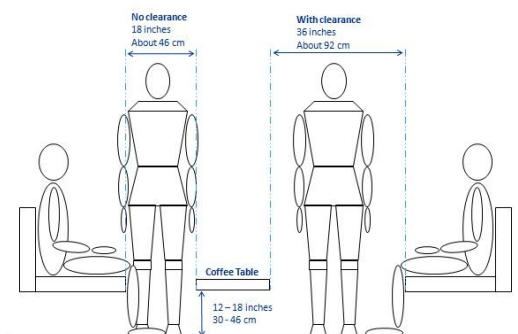

Image 2

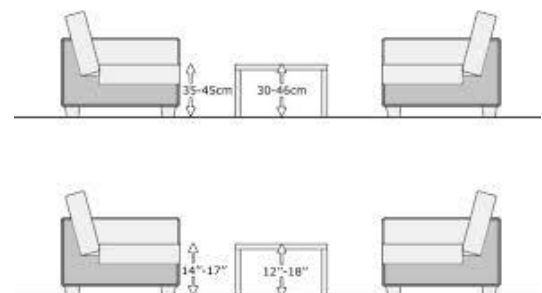

Image 3

Customize:

It will be used in a public sitting room or dining room as a general use coffee table whereby it will always be used by people as they sit and watch the television or used for entertaining guests for putting drinks or food on. The fact that the table is made from mdf it will be light weight and easy to move allowing the user to practically use it anywhere in the house. It will be used by the homeowner as a coffee table or a general us table in the house allowing them use for their own personal use.



Image 4

Location:

The table I will be manufacturing will be placed in any conventional sitting or dining room, for it to work best as a coffee table I will place it between two couches so that it can be accessed from both sides and possibly another couch at the end of the table so that it can fully reach its use as a table in a sitting room. As regards position in a room it will mainly be situated in the centre of the room so that it will be the main piece of furniture that will be used along with the couch.



Image 5

Style:

The table I will be manufacturing will have an elliptical top and from the curve I will get from the ellipse I will then use them as my legs which will show off a nice curved element which I think will give it a nice style. Below I will give a rough sketch and idea to what my final design table will look like. It will also give you a better understanding as to what style I am thinking of taking.

Visual impact:

I think my table will add to a positive visual impact on the room as I think it will welcome people in to use the table if they see a nice table and that it makes them comfortable as well as the seating. If the table matches the sitting room and that it is not out of proportion or size I think it will help the visual impact on the table and the room. Getting shape, size, and style right to fit a certain room isn't hard so if done right it will all go together helping everything in the room match with my table giving it a positive outcome as regards visual impact.



Image 6

Methodology:

The first stage of manufacturing the mdf table is to break out the pieces required for the table out of the half sheet of mdf which measures 1220mm x 1220mm x 18mm. once the timber is broke out to the rough cutting list sizes it is then ripped to the exact sizes that are required on the finished cutting list. When the timber is broke out to the finished sizes required the table top is marked out and cut using the band saw and the table top has a profile put on it using the hand router. Once the two legs have been cut into the two square sections I will then mark out the inscribed circle shape, it will be roughly cut on the band saw and the edges of the legs will be also finished with the hand router. After the table top and the two legs have been cut to size and routered I will then cut the shelf that will fit under the table top and rest on four notches that I will cut out of the legs. Cutting the notches for the shelf to rest on I will do with the band saw being accurate and cut them exactly, I will possibly also use one dowel in each four points where the shelf sits on to secure and basically just hold it in place. The shelf again will be finished with a square edge to it using the router. For the two legs to join I will cut out and notch out of the two so that they interlock with one another making them solid without the need for screws or glue. To join the table top to the legs I will use dowels, two on each leg which will support the table and the legs. I think the dowel joint will make the joining of the four legs to the table very simple and easy while also being strong enough to support whatever load that will be played on the table, I was also thinking of using the fox wedged joint that will have the tenon come true to the top of the table and then wedge it but I think it will take away from the look and style of the table giving it a negative look and effecting the visual impact of the table. There was other possible joints I was thinking of such as a housing joint underneath the table, but I think the dowels will have more of hold on the table top to the legs. I chose this joint because I feel it will suit this job perfect and do the job that it entails to do supporting the table. I believe this joint could also work on solid woods and also work perfect, I also believe the interlocking joint between the two legs could also work with solid woods if the grains were facing in the right way. I planned this table to manufacture it would be simple to assemble and cutting would be easy to do, due to the fact the table will be made from 18mm mdf I don't think there will be any need for a main support beam through the middle to support the middle of the table top as I think it will be strong enough for any weight applied.

Sketches:

Estimated time scale:

<u>Estimated time sheet scale:</u>	
Breaking out:	60 Mins
Marking out:	120 Mins
Cut top rough on band saw:	20 Mins
Cut legs rough on band saw:	40 Mins
Cut shelf:	20 Mins
Router edge on top:	30 Mins
Router curved edge on legs:	40 Mins
Cut interlocking squares out of legs:	20 Mins
Cut round corners on legs:	35 Mins
Cut/make joints to join legs and top:	40 Mins
Dry fit table:	15 Mins
Prepare table for finishing:	30 Mins
Total hours: roughly 8 hours	

Total of 32 hours for completion of mdf table.

Rough cutting list

Table top	905mm x 455mm
Large leg	805mm x 435mm
Small leg	390mm x 435mm
Shelf	520mm x 310mm

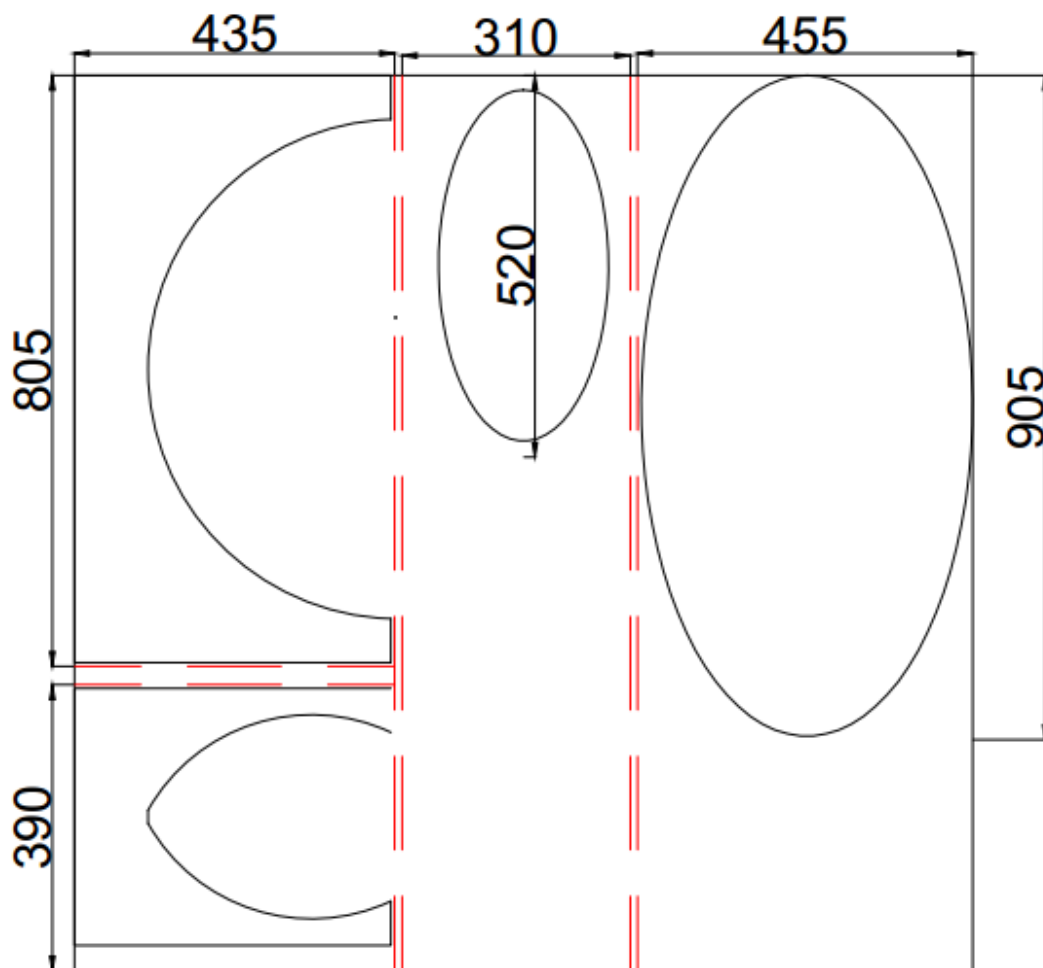

Finished cutting list

Table top	900mm x 450mm
Large leg	800mm x 430mm
Small leg	350mm x 430mm
Shelf	478mm x 231mm

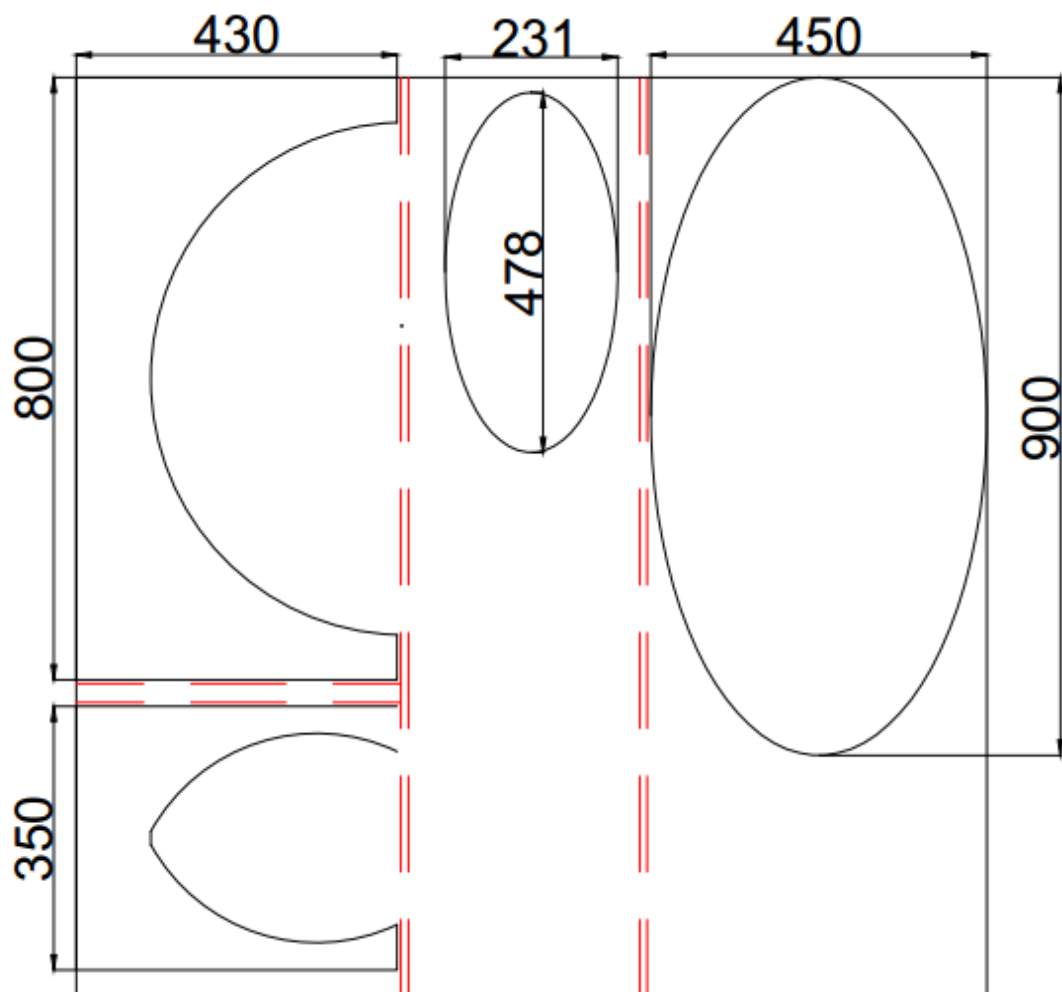

Sizes of each component:

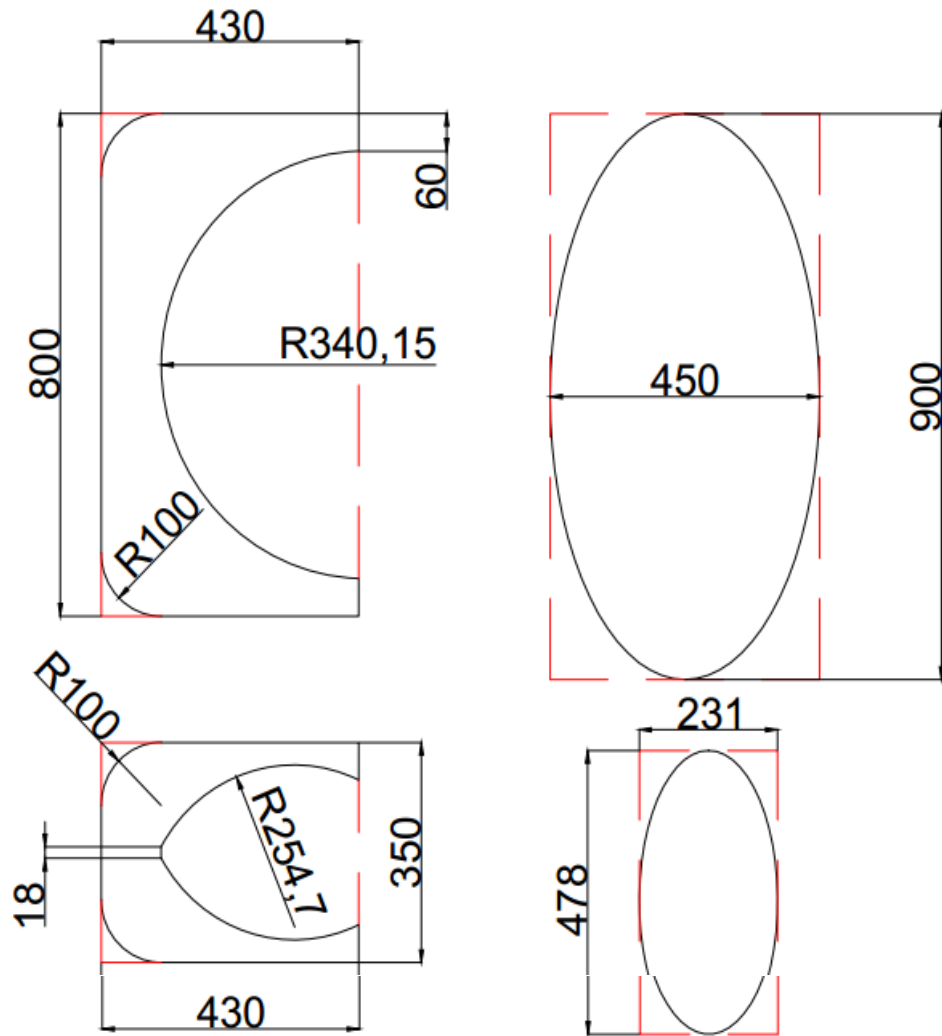

Works Cited:

<u>Image 1</u>	s3.amazonaws.com
<u>Image 2</u>	http://www.grandfurniture.co.uk
<u>Image 3</u>	173-254-32-136.unifiedlayer.com
<u>Image 4</u>	http://www.houzz.com
<u>Image 5</u>	gcims.com
<u>Image 6</u>	woodenitbeamazing.com